



**FIG 400 HAMMER UNION**  
**4000 PSI NSCWP**  
**FORGED STEEL HAMMER UNION**

**METAL-TO-METAL SEAL**

**WOG UP TO 4000 PSI**

**NPT THREADED CONNECTIONS**

Standard Service	
NSCWP	TEST
4000	6000

PART#	A (in)	B	WT (lbs)
A400T-2.0	3.64	5.24	12.00
A400T-3.0	4.19	6.25	19.25
A400T-4.0	5.00	8.13	32.00

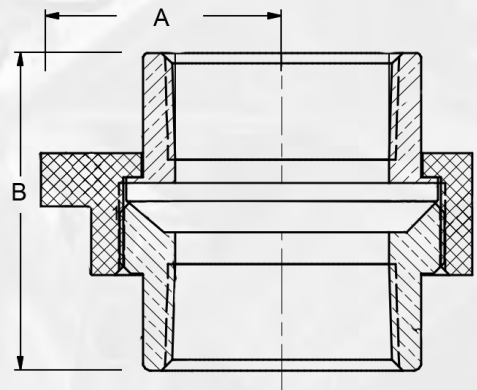

PART#	NPT	Material		
		M SUB	F SUB	NUT
A400T-2.0	2"	A105	A105	CS
A400T-3.0	3"	A105	A105	CS
A400T-4.0	4"	1020	1020	1020





## PRODUCT WARNINGS

**Pressure containing piping components are dangerous if used incorrectly. Please observe all industry safety standards and common sense when working around any pressure containing equipment. Failure to do so can result in serious bodily injury or death.**

Do not exceed recommended working pressure rating

Do not mix and match components of different pressure ratings. Mismatching unions can fail explosively and resulting in property damage, injury or death

Do not strike a hammer union that is under pressure

Do not use a union that is worn, damaged or deteriorated in any way

Do not mix match standard and sour gas service products. Standard service equipment is not suitable for sour applications

Do not use Apache products in overhead suspension applications

Do make sure the piping system is depressurized when disassembling union connections

Do properly identify the figure number and pressure rating when selecting a union for service

Do take extra care when working in ambient temperatures below freezing. Low temperature reduces the ductility and impact strength of iron and steel

Do wear appropriate protective equipment when installing and disassembling Apache products

Do remove leaking components immediately

Do remove from service and disposed any equipment where positive identification of product's size, figure, and pressure rating is not possible due to deterioration. or other damages